

NEXT ASSEMBLY

ISSUE	REVISION RECORD	DATE	APPD.
-------	-----------------	------	-------

15MTC/1529 TIEDOWN ASSEMBLY (CARGO)

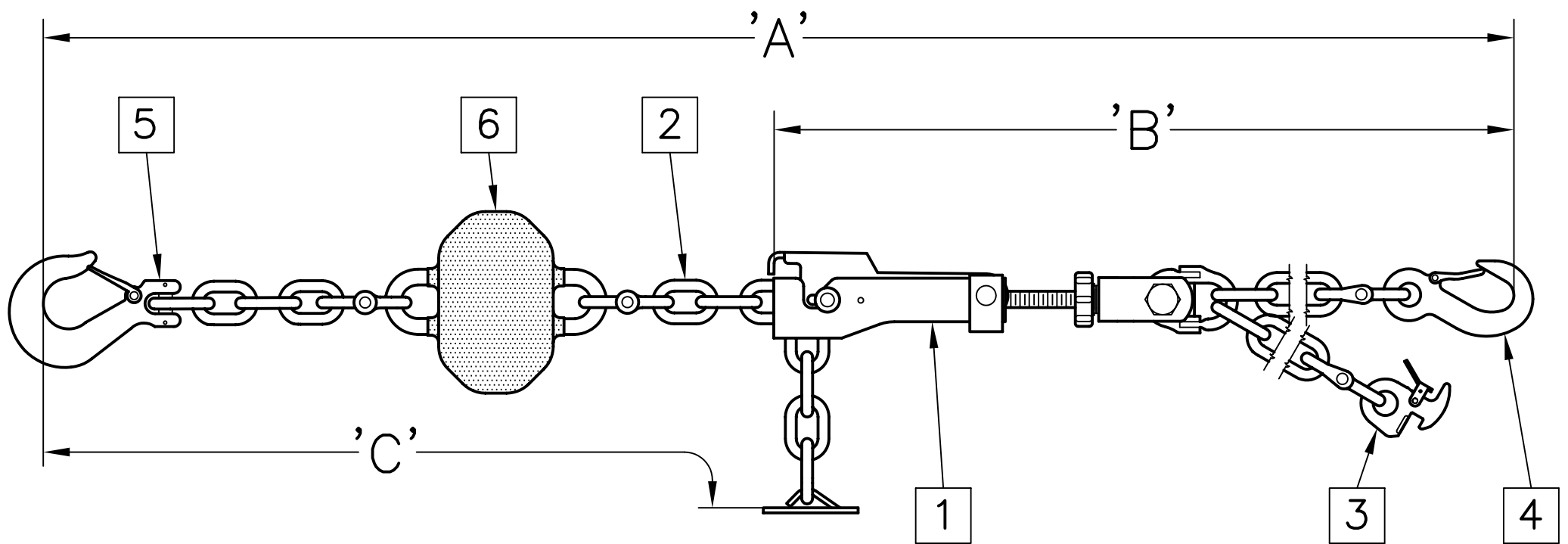

SPECIFICATIONS

MATERIAL:
ALL CONSTRUCTION IS PER BEST COMMERCIAL QUALITY. SEE CHART FOR SPECIFIC MATERIAL.

STRENGTH:
SAFE WORKING—4,100 LBS.
PROOF—8,200 LBS.
MINIMUM BREAK—14,400 LBS.

FINISH:
ALL SURFACE FINISHES PROVIDE GOOD CORROSION PROTECTION. SEE CHART FOR SPECIFIC FINISH.

WEIGHT:
7.3 KGS. [16.0 LBS.]

COMPLETE ASSEMBLY	
MODEL NO.	USEABLE LENGTH 'A'
15MTC/1529	39.0" TO 84.0"

TENSIONER ASSEMBLY	
MODEL NO.	USEABLE LENGTH 'B'
15MTC-1/1529	20.0" TO 21.75"

CHAIN ASSEMBLY	
MODEL NO.	DIM. 'C'
15MTC-2/1529	72.0"

15MTC/1529 TIEDOWN ASSEMBLY (CARGO)

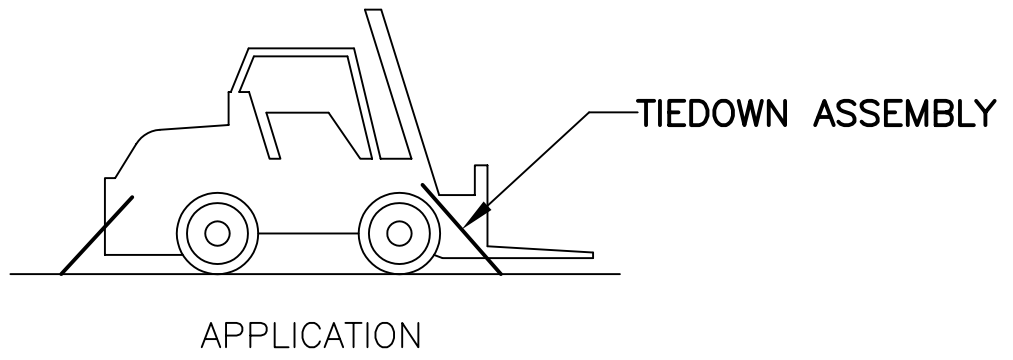

ITEM NO.	PART NAME	PART DESCRIPTION
6	SHOCK MITIGATOR	CHAIN/ELASTOMER COMPOUND
5	HOOK	STEEL, ZINC PLATED
4	HOOK	STEEL, ZINC PLATED
3	HOOK	STEEL, ZINC PLATED
2	CHAIN	STEEL, ZINC PLATED
1	TENSIONER	STEEL, ZINC PLATED

LIST OF COMPONENTS

PECK & HALE
180 DIVISION AVENUE
W. SAYVILLE, N.Y. 11796 U.S.A.

THIS DRAWING AND ANY PRINT MADE THEREFROM IS THE EXCLUSIVE PROPERTY OF PECK & HALE, IT MUST NOT BE TRACED NOR REPRODUCED IN ANY MANNER NOR SHALL IT BE SUBMITTED TO OUTSIDE PARTIES FOR EXAMINATION WITHOUT OUR WRITTEN CONSENT. IT SHALL BE USED ONLY AS MEANS OF REFERENCE TO WORK DESIGNED OR FURNISHED BY US.

FSCM No: 94658	DRN: S. JEFFREY	SHEET	OF
DATE: 11/12/12	CHK:	3986	DWG. NO.
SCALE: NONE	APPD:		