

E.W.O. 3443
 R.T.E. 1003
 R.T.E. 1006
 R.T.E. 1687
 R.T.E. 1688

F187-20/-2 'D'-RING & STRAP

DIMENSIONAL DATA
 DIMENSIONS SHOWN IN INCHES AND [MILLIMETERS]
 DIMENSIONS ARE REFERENCE ONLY

SPECIFICATIONS

MATERIAL:
 STEEL

STRENGTH: (PULL AT 45°)
 SAFE WORKING-10,000 LBS.
 PROOF-11,000 LBS.
 MINIMUM BREAK-20,000 LBS.

FINISH:
 SELF COLOR

WEIGHT:
 0.45 KGS. (1.0 LBS.)

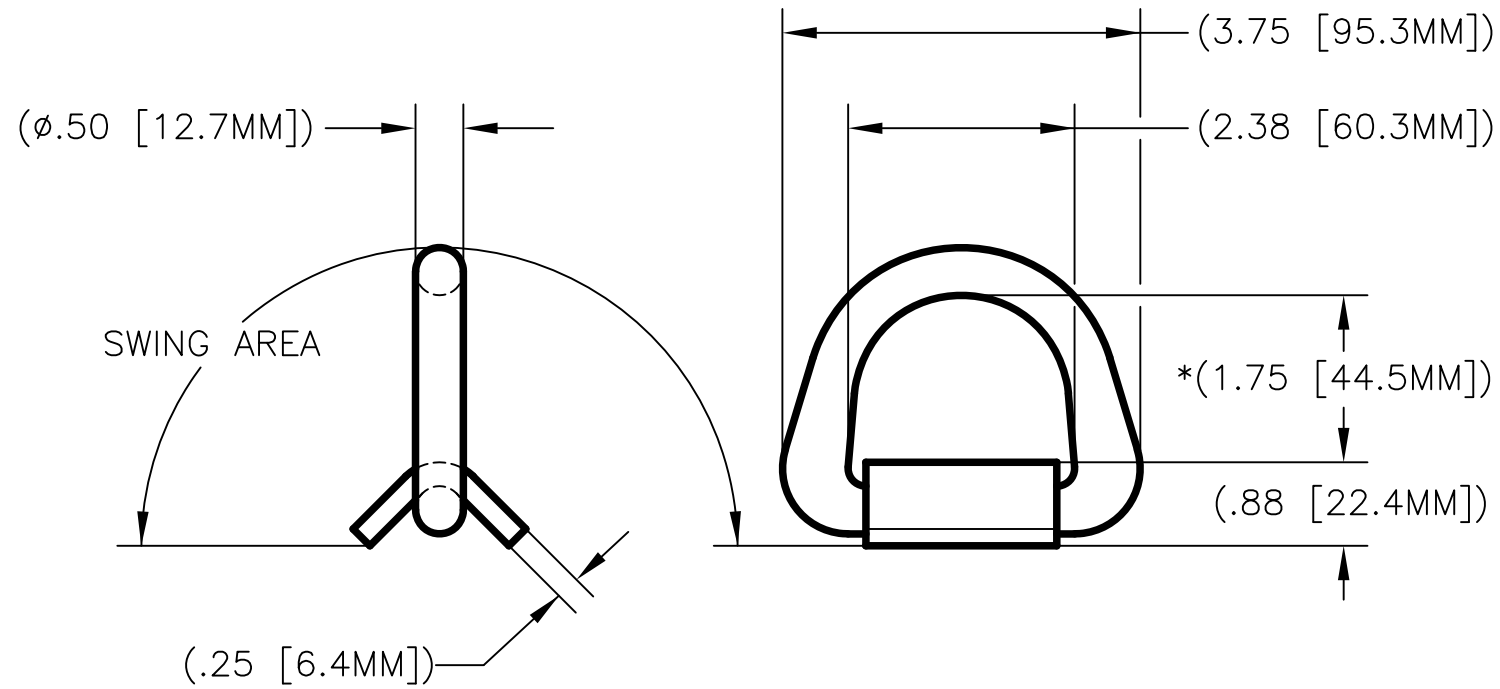
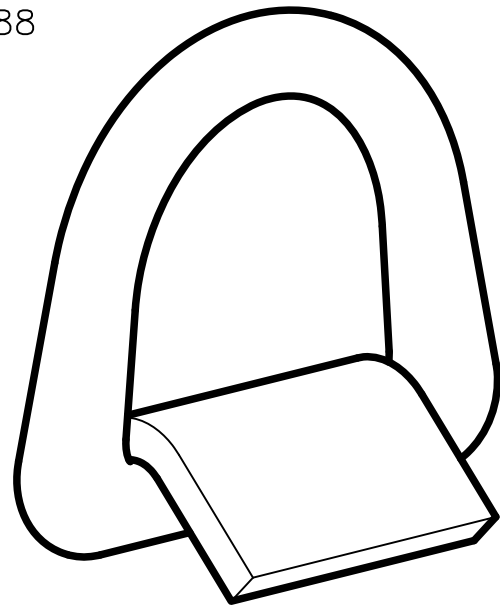

*DIMENSION IS WITH 'D'-RING IN TENSION

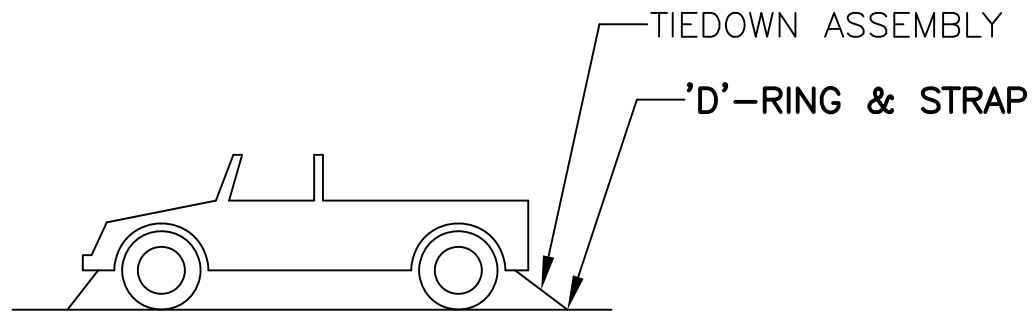

APPLICATION

F187-20/-2 'D'-RING & STRAP



PECK & HALE, L.L.C.
 180 DIVISION AVENUE
 WEST SAYVILLE, NY 11796
 USA

THIS DRAWING AND ANY PRINT MADE THEREFROM IS THE EXCLUSIVE PROPERTY OF PECK & HALE. IT MUST NOT BE TRACED NOR REPRODUCED IN ANY MANNER NOR SHALL IT BE SUBMITTED TO OUTSIDE PARTIES FOR EXAMINATION WITHOUT OUR WRITTEN CONSENT. IT SHALL BE USED ONLY AS MEANS OF REFERENCE TO WORK DESIGNED OR FURNISHED BY US.

FSCM NO: 94658	DRN: S. JEFFREY	3068	A
DATE: 3/26/13	CHK:		
SCALE: NONE	APPD:	DWG. NO.	REV.