

F273-1-0F SOCKET (I.S.O.-FLUSH-SINGLE)

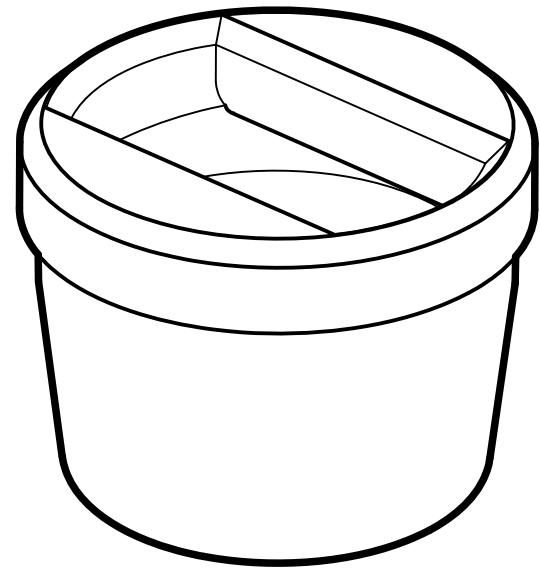

DIMENSIONAL DATA
DIMENSIONS SHOWN IN INCHES AND [MILLIMETERS]
DIMENSIONS ARE REFERENCE ONLY

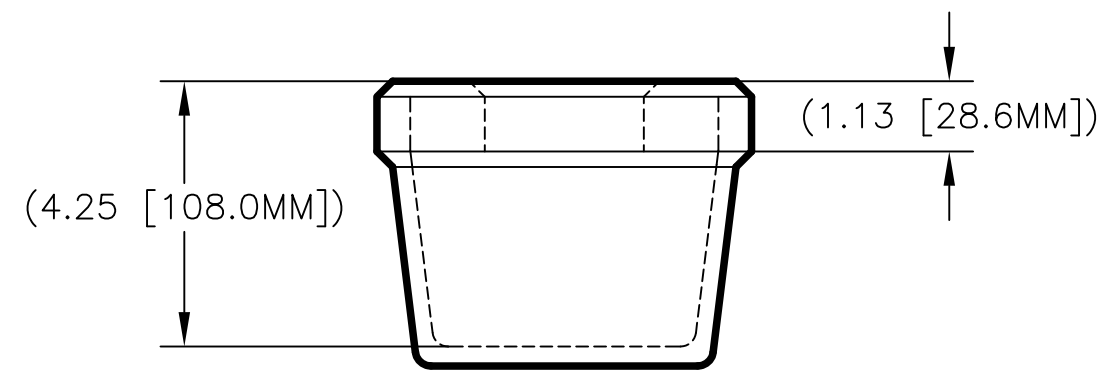
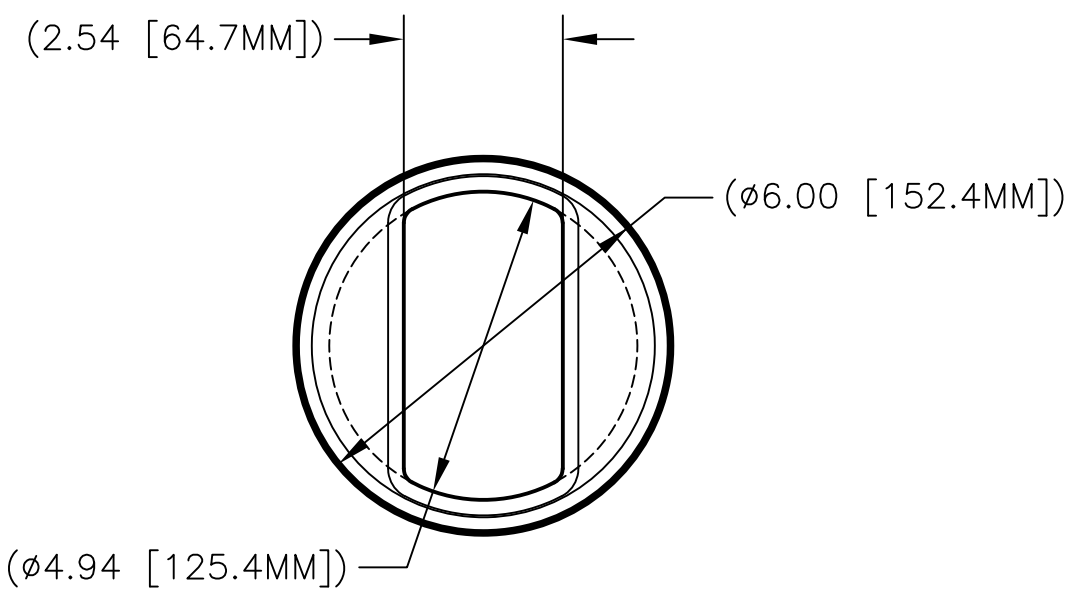

SPECIFICATIONS

MATERIAL:
STEEL

STRENGTH: (TONNES)

	TENSION	SHEAR	COMPRESSION
SAFE WORKING-	25	25	75
PROOF-	37.5	37.5	112.5
MINIMUM BREAK-	50	50	150

FINISH:
SELF COLOR

WEIGHT:
5.3 KGS. (11.7 LBS.)

MATING FITTINGS:
PH2931-2B-PG COVER
F476 & F633 TWISTLOCK
F483 'D'-RING

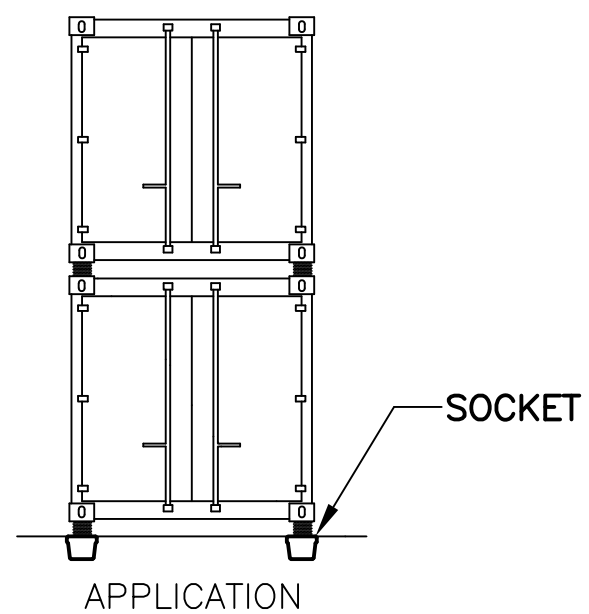

**F273-1-0F
SOCKET
(I.S.O.-FLUSH-SINGLE)**

Peck & Hale® PECK & HALE, L.L.C.
180 DIVISION AVENUE
WEST SAYVILLE, NY 11796
USA
Cargo Securing Systems and Solutions

THIS DRAWING AND ANY PRINT MADE THEREFROM IS THE EXCLUSIVE PROPERTY OF PECK & HALE. IT MUST NOT BE TRACED NOR REPRODUCED IN ANY MANNER NOR SHALL IT BE SUBMITTED TO OUTSIDE PARTIES FOR EXAMINATION WITHOUT OUR WRITTEN CONSENT. IT SHALL BE USED ONLY AS MEANS OF REFERENCE TO WORK DESIGNED OR FURNISHED BY US.

FSCM NO: 94658	DRN: S. JEFFREY	3484	A
DATE: 11/6/12	CHK: J. SZEGLIN		
SCALE: NONE	APPD: J. SZEGLIN	DWG. NO.	REV.