

E.W.O. 3006

F3800-1 STACKER (SAFETY-FIXED BASE)

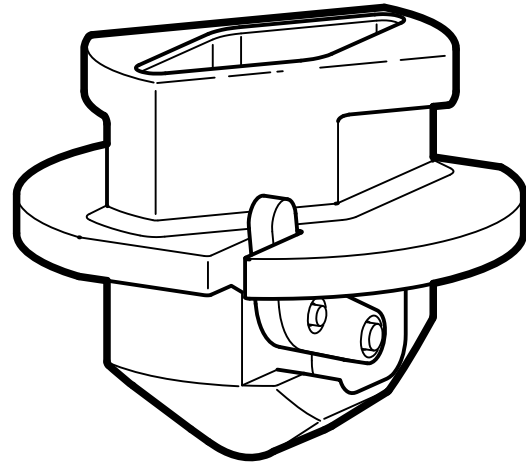

DIMENSIONAL DATA
DIMENSIONS SHOWN IN INCHES AND [MILLIMETERS]
DIMENSIONS ARE REFERENCE ONLY

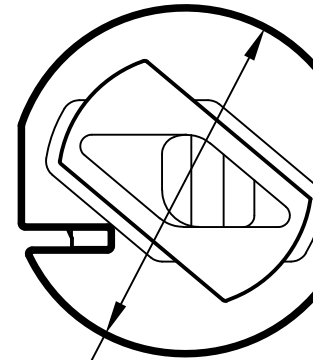

(ϕ 5.91 [150.0MM])

(2.28 [58.0MM])

(.47 [12.0MM])

(2.28 [58.0MM])

(4.33 [110.0MM])

SPECIFICATIONS

MATERIAL:
STEEL

STRENGTH: (MINIMUM BREAK)
SHEAR-35 TONNES
COMPRESSION-150 TONNES

FINISH:
GALVANIZED

WEIGHT:
4.1 KGS. (9.1 LBS.)

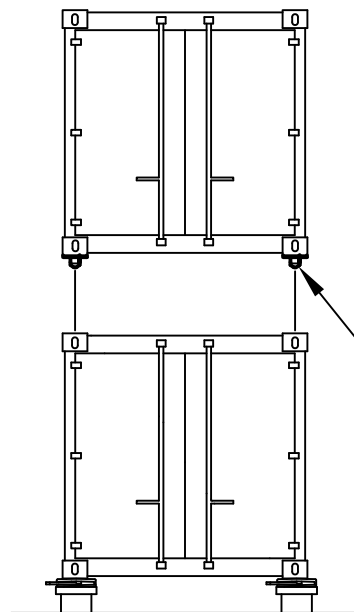

STACKER

APPLICATION

F3800-1 STACKER (SAFETY-FIXED BASE)

Peck & Hale[®]
Cargo Securing Systems and Solutions

PECK & HALE, L.L.C.
180 DIVISION AVENUE
WEST SAYVILLE, NY 11796
USA

THIS DRAWING AND ANY PRINT MADE THEREFROM IS THE EXCLUSIVE PROPERTY OF PECK & HALE. IT MUST NOT BE TRACED NOR REPRODUCED IN ANY MANNER NOR SHALL IT BE SUBMITTED TO OUTSIDE PARTIES FOR EXAMINATION WITHOUT OUR WRITTEN CONSENT. IT SHALL BE USED ONLY AS MEANS OF REFERENCE TO WORK DESIGNED OR FURNISHED BY US.

FSCM NO: 94658	DRN: S. JEFFREY	4357	A
DATE: 11/15/12	CHK: J. SZEGLIN		
SCALE: NONE	APPD:	DWG. NO.	REV.