

F643-1/-2 'D'-RING & STRAP

DIMENSIONAL DATA
DIMENSIONS SHOWN IN INCHES AND [MILLIMETERS]
DIMENSIONS ARE REFERENCE ONLY

SPECIFICATIONS

MATERIAL:
STEEL

STRENGTH: (PULL AT 45°)
SAFE WORKING-55,100 LBS.
PROOF-73,393 LBS.
MINIMUM BREAK-110,200 LBS.

FINISH:
SELF COLOR

WEIGHT:
4.7 KGS. (10.3 LBS.)

SALES DRAWING

F643-1/-2 'D'-RING & STRAP

Peck & Hale®
Cargo Securing Systems and Solutions

PECK & HALE, L.L.C.
180 DIVISION AVENUE
WEST SAYVILLE, NY 11796
USA

THIS DRAWING AND ANY PRINT MADE THEREFROM IS THE EXCLUSIVE PROPERTY OF PECK & HALE. IT MUST NOT BE TRACED NOR REPRODUCED IN ANY MANNER NOR SHALL IT BE SUBMITTED TO OUTSIDE PARTIES FOR EXAMINATION WITHOUT OUR WRITTEN CONSENT. IT SHALL BE USED ONLY AS MEANS OF REFERENCE TO WORK DESIGNED OR FURNISHED BY US.

FSCM NO: 94658	DRN: S. JEFFREY	3491	A
DATE: 11/6/12	CHK: J. SZEGLIN		
SCALE: NONE	APPD: J. SZEGLIN		
		DWG. NO.	REV.

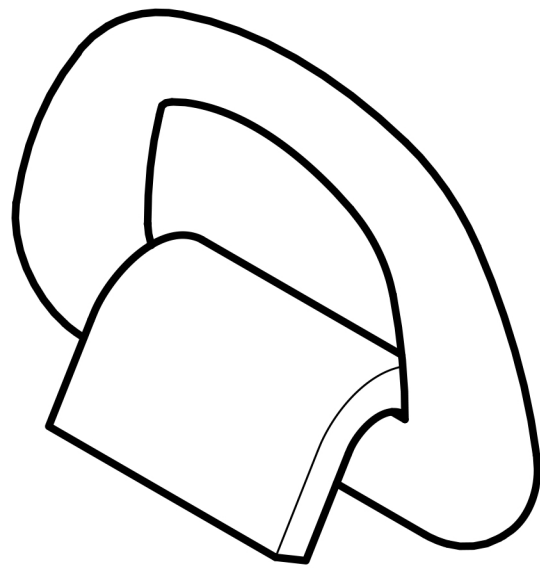

(ø1.00 [25.4MM])

SWING AREA

(.63 [16.0MM])

*DIMENSION IS WITH 'D'-RING IN TENSION

(8.75 [222.3MM])

(5.00 [127.0MM])

*(3.00 [76.2MM])

(2.04 [51.9MM])

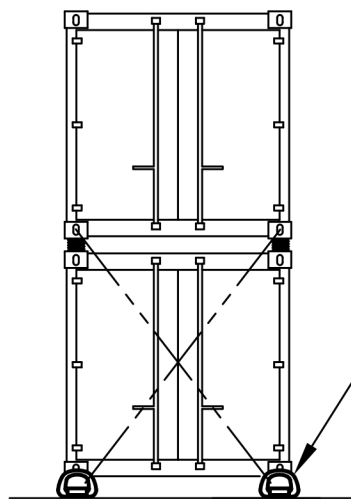

'D'-RING & STRAP

APPLICATION