

# F654-1/-2 'D'-RING & STRAP

DIMENSIONAL DATA  
DIMENSIONS SHOWN IN INCHES AND [MILLIMETERS]  
DIMENSIONS ARE REFERENCE ONLY

## SPECIFICATIONS

**MATERIAL:**  
STEEL

**STRENGTH:** (PULL AT 45°)  
SAFE WORKING-54,000 LBS.  
PROOF-60,000 LBS.  
MINIMUM BREAK-90,000 LBS.

**FINISH:**  
SELF COLOR

**WEIGHT:**  
3.5 KGS. (7.6 LBS.)

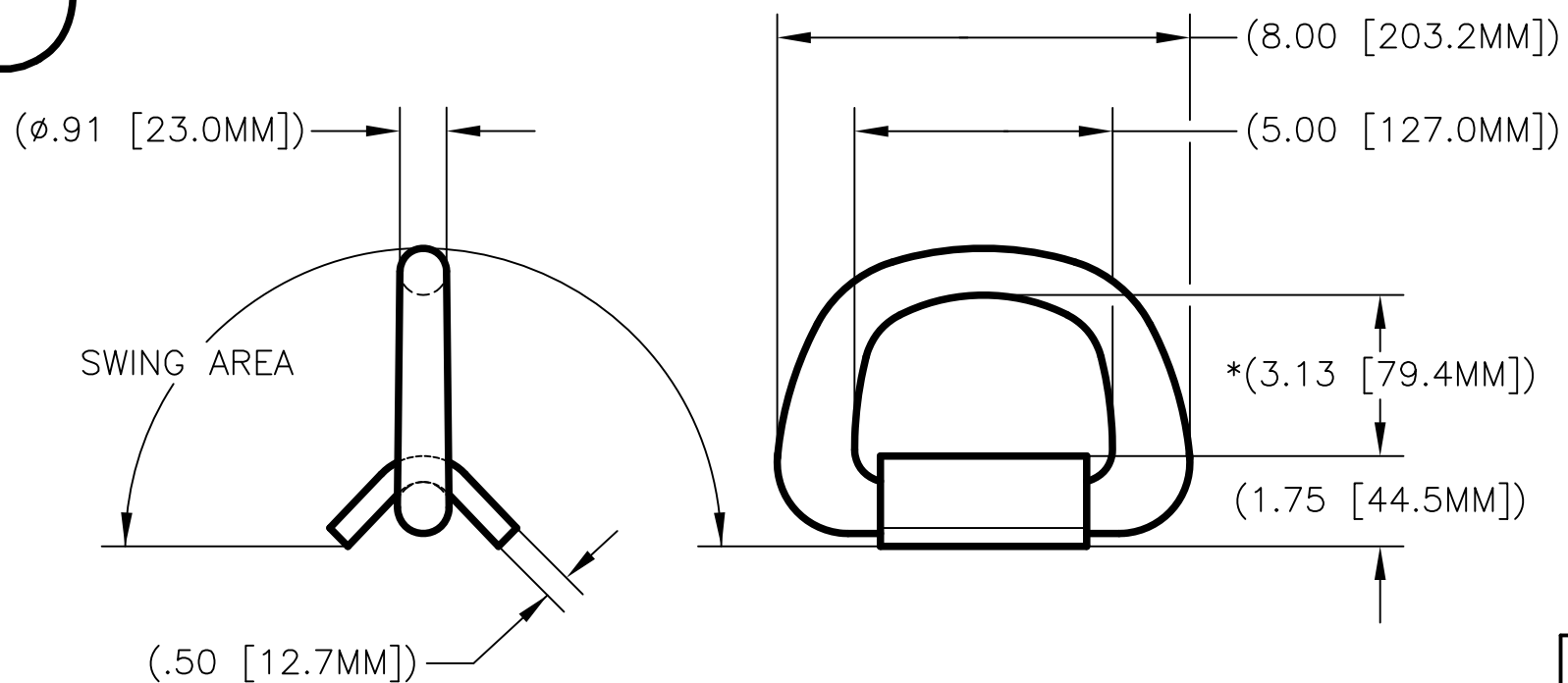
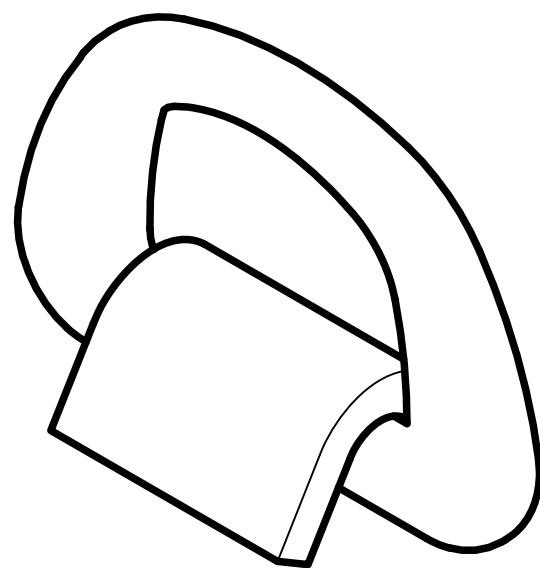

\*DIMENSION IS WITH 'D'-RING IN TENSION

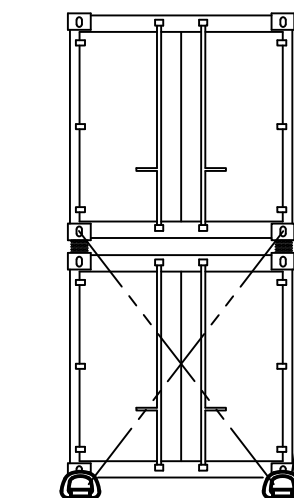

APPLICATION

# F654-1/-2 'D'-RING & STRAP

**Peck & Hale**®  
Cargo Securing Systems and Solutions

PECK & HALE, L.L.C.  
180 DIVISION AVENUE  
WEST SAYVILLE, NY 11796  
USA

THIS DRAWING AND ANY PRINT MADE THEREFROM IS THE EXCLUSIVE PROPERTY OF PECK & HALE. IT MUST NOT BE TRACED NOR REPRODUCED IN ANY MANNER NOR SHALL IT BE SUBMITTED TO OUTSIDE PARTIES FOR EXAMINATION WITHOUT OUR WRITTEN CONSENT. IT SHALL BE USED ONLY AS MEANS OF REFERENCE TO WORK DESIGNED OR FURNISHED BY US.

FSCM NO: 94658	DRN: S. JEFFREY	3491	A
DATE: 11/6/12	CHK: J. SZEGLIN		
SCALE: NONE	APPD: J. SZEGLIN	DWG. NO.	REV.