

E.W.O. 1999

# MK5A-1L & 2R CONTAINER LIFTING LUG (BOTTOM CAMLOCK)

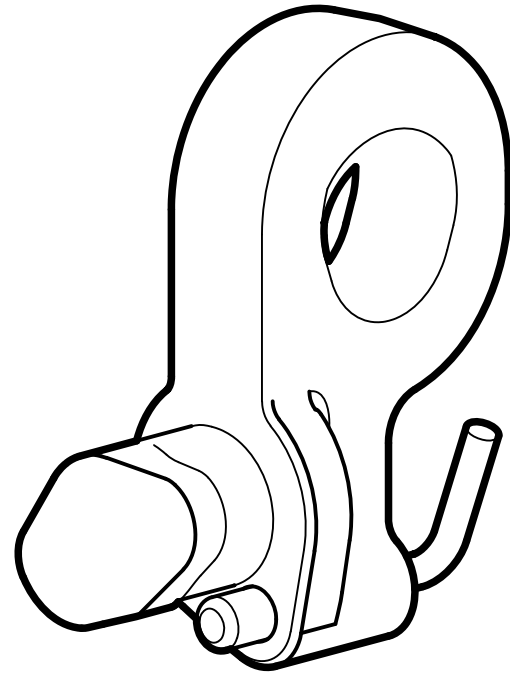

DIMENSIONAL DATA  
DIMENSIONS SHOWN IN INCHES AND [MILLIMETERS]  
DIMENSIONS ARE REFERENCE ONLY

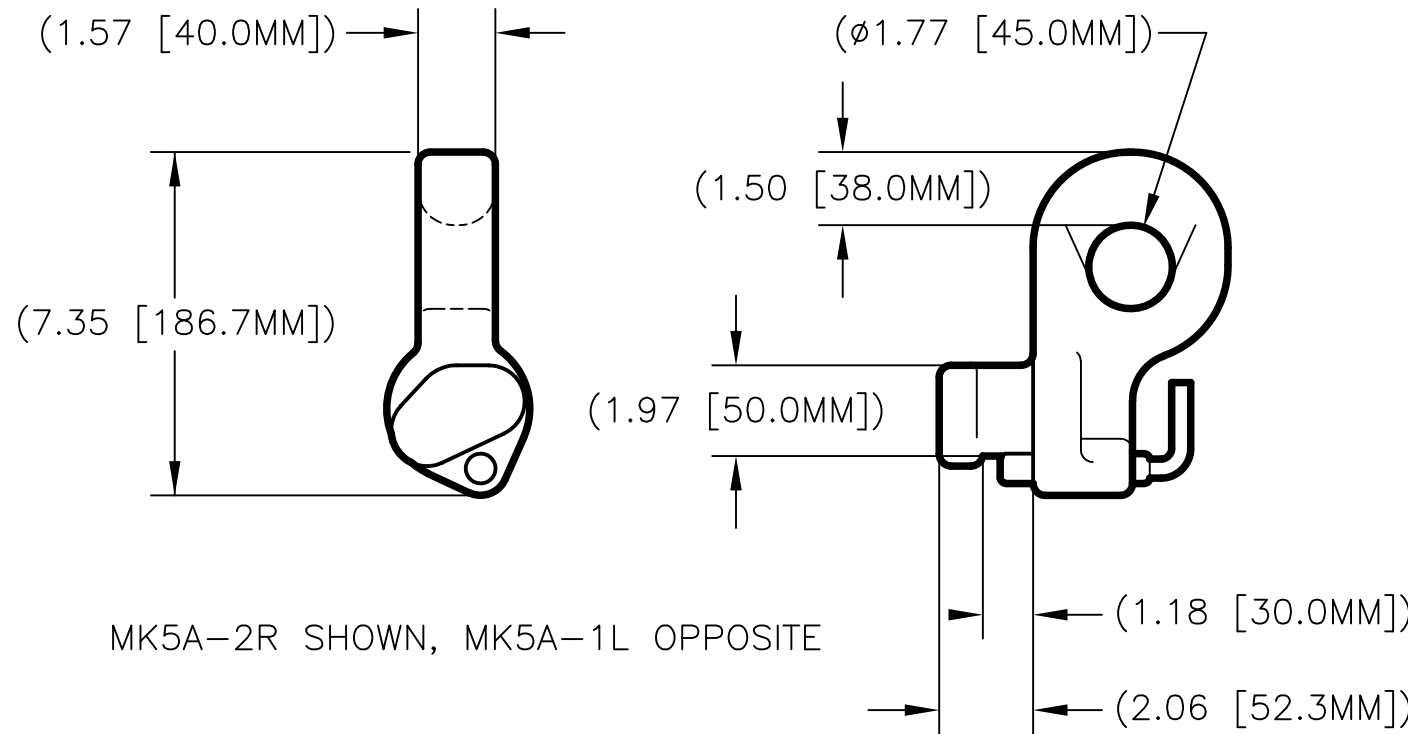

## SPECIFICATIONS

**MATERIAL:**  
STEEL

**STRENGTH:** (SET OF 4)  
SAFE WORKING-32 TONNES AT MAX.  
ANGLE OF 50° FROM VERTICAL  
SAFE WORKING-40 TONNES AT MAX.  
ANGLE OF 35° FROM VERTICAL

**FINISH:**  
PAINTED (COLOR-YELLOW)

**WEIGHT:**  
4.7 KGS. (10.3 LBS.)

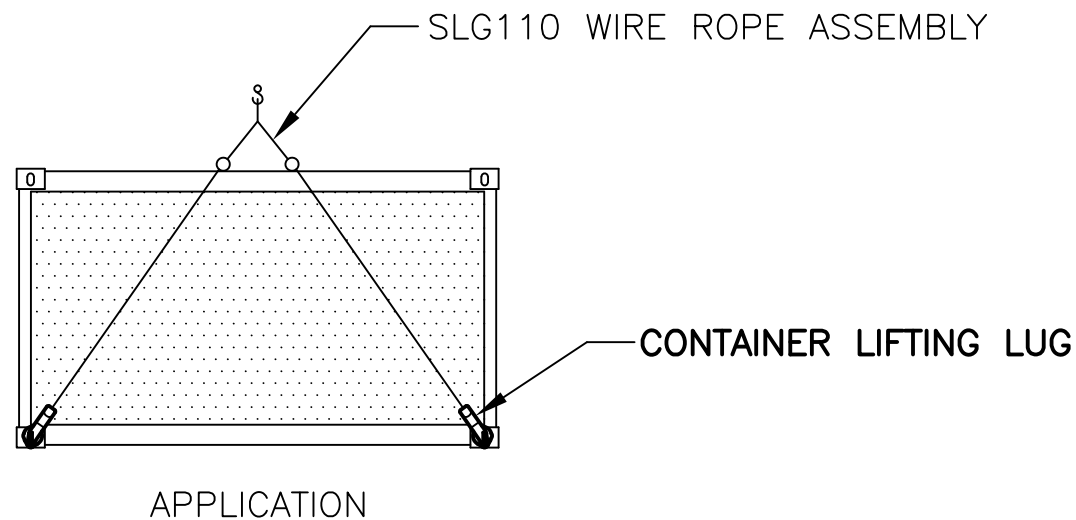

# MK5A-1L & -2R CONTAINER LIFTING LUG (BOTTOM CAMLOCK)

**Peck & Hale**®  
Cargo Securing Systems and Solutions

PECK & HALE, L.L.C.  
180 DIVISION AVENUE  
WEST SAYVILLE, NY 11796  
USA

THIS DRAWING AND ANY PRINT MADE THEREFROM IS THE EXCLUSIVE PROPERTY OF PECK & HALE. IT MUST NOT BE TRACED NOR REPRODUCED IN ANY MANNER NOR SHALL IT BE SUBMITTED TO OUTSIDE PARTIES FOR EXAMINATION WITHOUT OUR WRITTEN CONSENT. IT SHALL BE USED ONLY AS MEANS OF REFERENCE TO WORK DESIGNED OR FURNISHED BY US.

FSCM NO: 94658	DRN: S. JEFFREY	3990	A
DATE: 8/7/14	CHK:		
SCALE: NONE	APPD:	DWG. NO.	REV.