

E.W.O. 4009

PH285N-14 SOCKET (CROSSBAR-FLUSH)

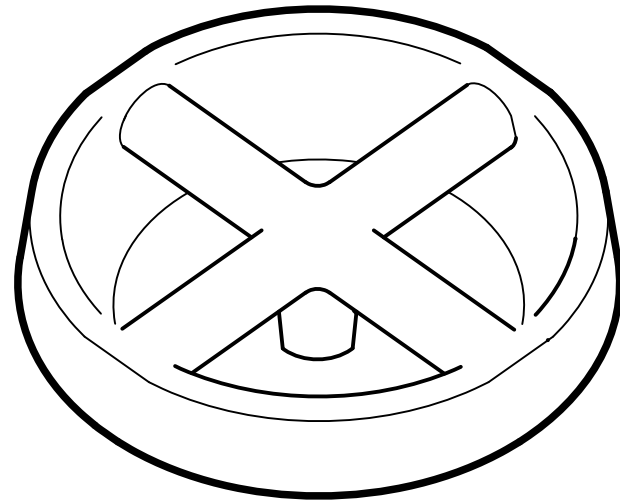

DIMENSIONAL DATA
DIMENSIONS SHOWN IN INCHES AND [MILLIMETERS]
DIMENSIONS ARE REFERENCE ONLY

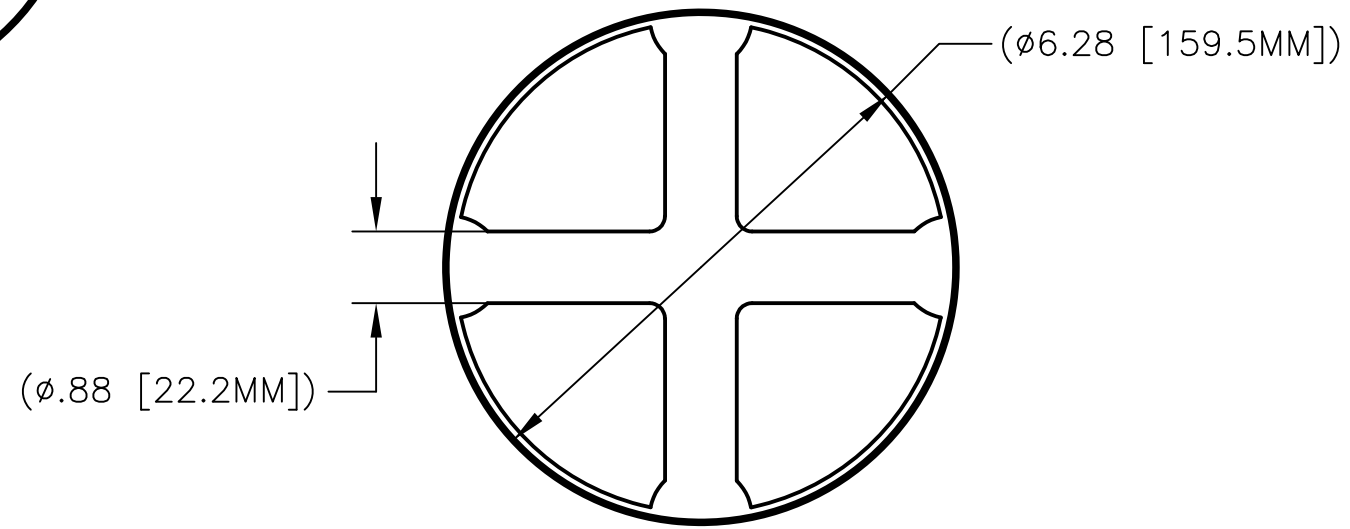

SPECIFICATIONS

MATERIAL:
STEEL

FINISH:
PRIMER PAINT OR SELF COLOR

WEIGHT:
3.0 KGS. (6.7 LBS.)

MATING FITTINGS:
PH285-30B & PH4243-1 COVERS

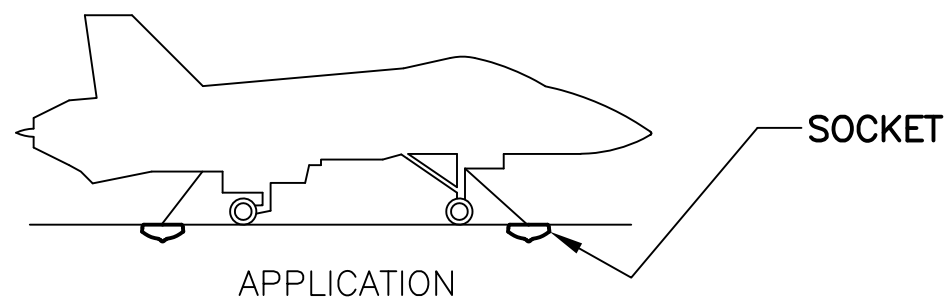
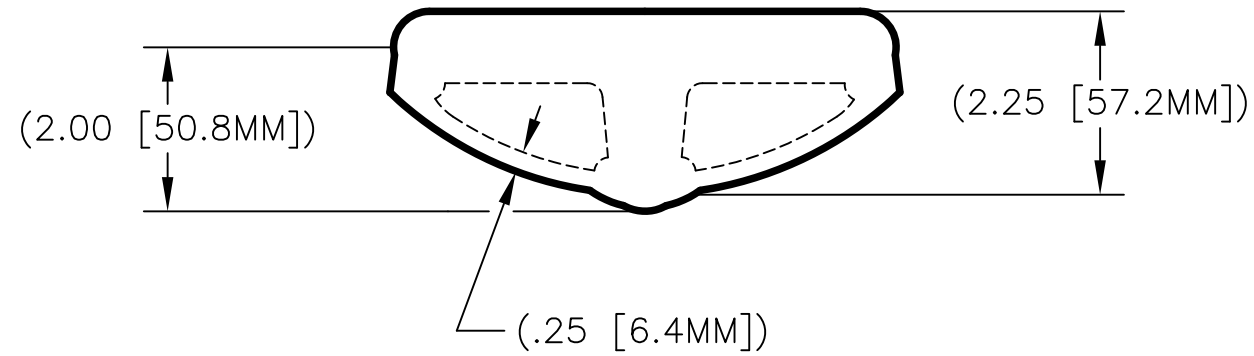

PH285N-14 SOCKET (CROSSBAR-FLUSH)

Peck & Hale®
Cargo Securing Systems and Solutions

PECK & HALE, L.L.C.
180 DIVISION AVENUE
WEST SAYVILLE, NY 11796
USA

THIS DRAWING AND ANY PRINT MADE THEREFROM IS THE EXCLUSIVE PROPERTY OF PECK & HALE. IT MUST NOT BE TRACED NOR REPRODUCED IN ANY MANNER NOR SHALL IT BE SUBMITTED TO OUTSIDE PARTIES FOR EXAMINATION WITHOUT OUR WRITTEN CONSENT. IT SHALL BE USED ONLY AS MEANS OF REFERENCE TO WORK DESIGNED OR FURNISHED BY US.

| | | | |
|----------------|-------------------|----------|------|
| FSCM NO: 94658 | DRN: S. JEFFREY | 3495 | A |
| DATE: 9/28/16 | CHK: L. MESZAROS | | |
| SCALE: NONE | APPD: L. MESZAROS | DWG. NO. | REV. |