

E.W.O. 4311

# PH3993 'D'-RING FITTING (CLOVERLEAF BASE)

DIMENSIONAL DATA  
DIMENSIONS SHOWN IN INCHES AND [MILLIMETERS]  
DIMENSIONS ARE REFERENCE ONLY

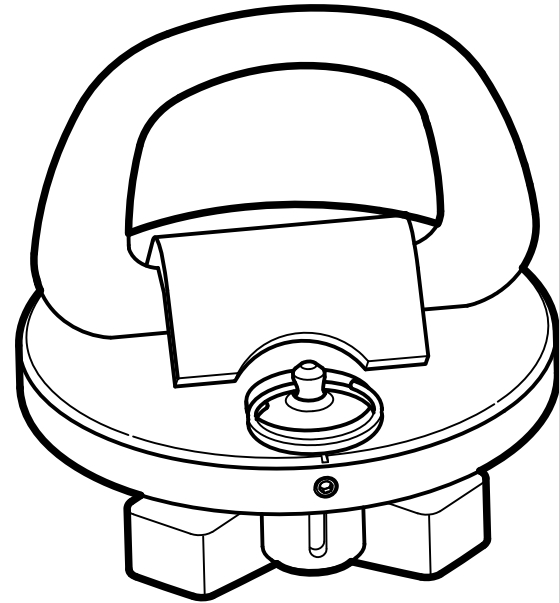

( $\phi$ 8.50 [216.0MM])

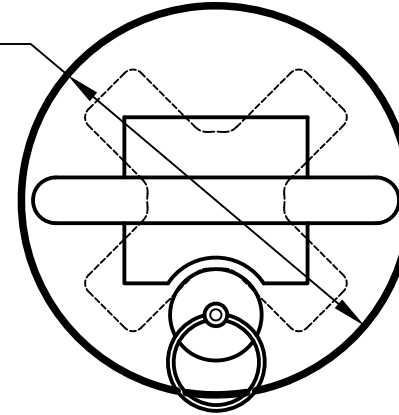

## SPECIFICATIONS

**MATERIAL:**  
STEEL

**STRENGTH:** (PULL AT 45°)  
SAFE WORKING—4,500 LBS.  
PROOF—9,000 LBS.  
MINIMUM BREAK—18,000 LBS.

**FINISH:**  
ZINC PRIMER/POWDER COAT  
(COLOR—YELLOW)

**WEIGHT:**  
SEE 'WEIGHT' IN CHART

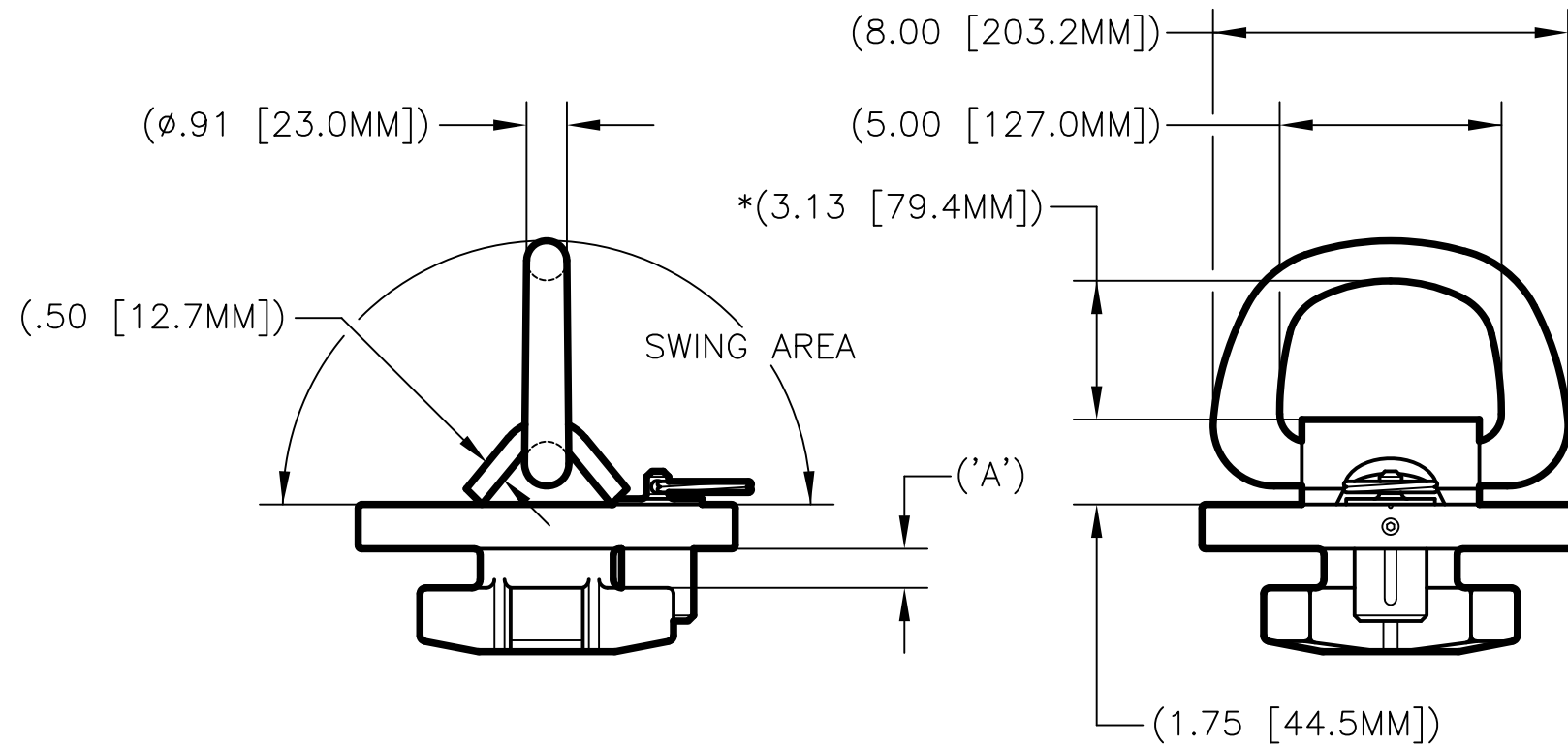

\*DIMENSION IS WITH 'D'-RING IN TENSION

PART NO.	'A'	WEIGHT
PH3993-5-1	.96 [24.4MM]	13.77 KGS. (30.3 LBS.)
PH3993-4-1	.88 [22.4MM]	13.91 KGS. (30.6 LBS.)

# PH3993 'D'-RING FITTING (CLOVERLEAF BASE)

**Peck & Hale**<sup>®</sup>  
Cargo Securing Systems and Solutions

PECK & HALE, L.L.C.  
180 DIVISION AVENUE  
WEST SAYVILLE, NY 11796  
USA

THIS DRAWING AND ANY PRINT MADE THEREFROM IS THE EXCLUSIVE PROPERTY OF PECK & HALE. IT MUST NOT BE TRACED NOR REPRODUCED IN ANY MANNER NOR SHALL IT BE SUBMITTED TO OUTSIDE PARTIES FOR EXAMINATION WITHOUT OUR WRITTEN CONSENT. IT SHALL BE USED ONLY AS MEANS OF REFERENCE TO WORK DESIGNED OR FURNISHED BY US.

FSCM NO: 94658	DRN: S. JEFFREY	4890	REV.
DATE: 12/11/18	CHK: A. CRENNAN		
SCALE: NONE	APPD: C. EFSTATHIOU	DWG. NO.	