

E.W.O. 1936  
 E.W.O. 1980  
 R.T.E. 1413

# SLG106-5 SLING

DIMENSIONAL DATA  
 DIMENSIONS SHOWN IN INCHES AND [MILLIMETERS]  
 DIMENSIONS ARE REFERENCE ONLY

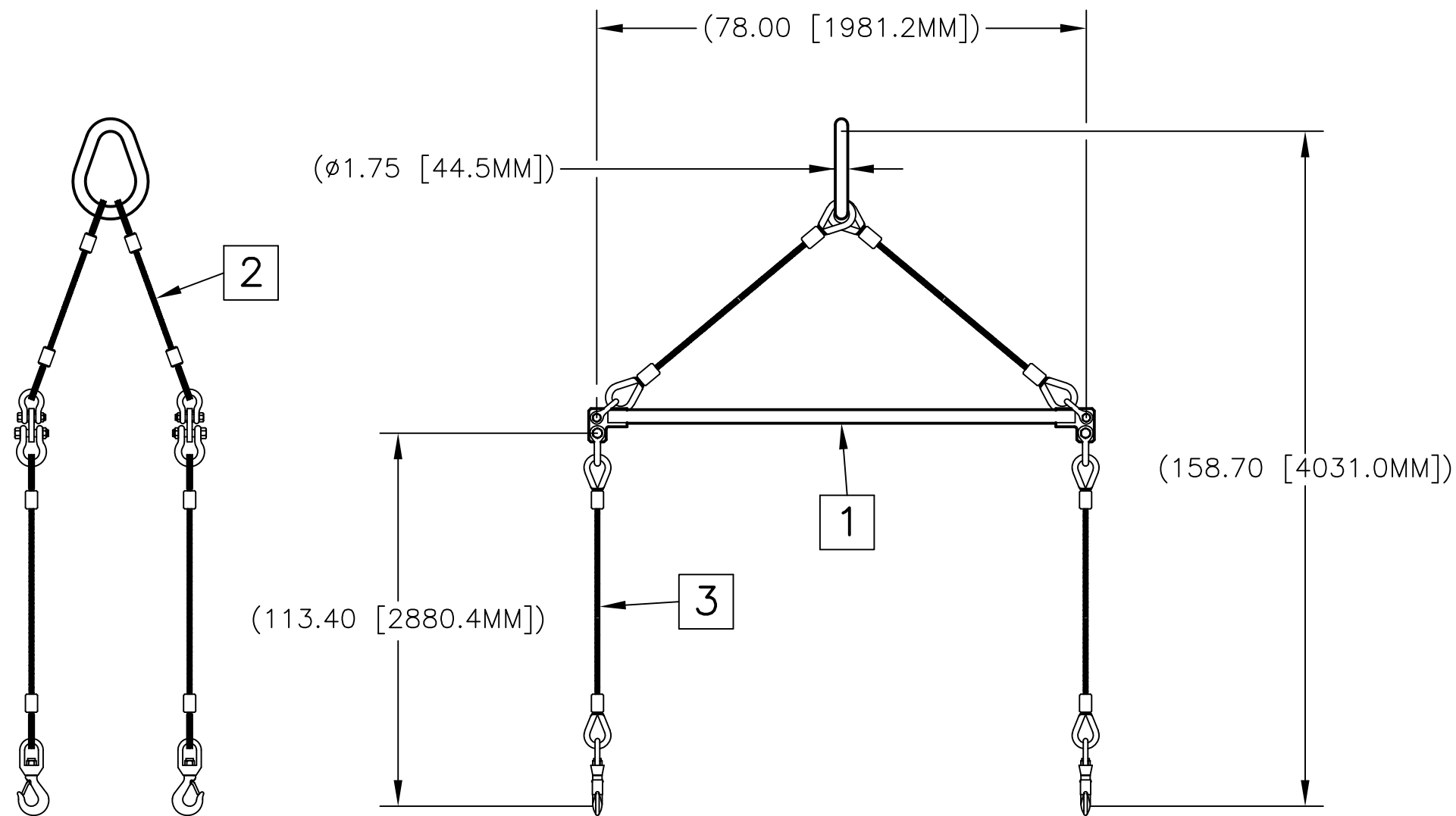

## SPECIFICATIONS

**MATERIAL:**  
 ALL CONSTRUCTION IS PER BEST  
 COMMERCIAL QUALITY. SEE CHART  
 FOR SPECIFIC MATERIAL.

**STRENGTH:**  
 RATED CAPACITY-10,000 LBS.

**FINISH:**  
 ALL SURFACE FINISHES PROVIDE GOOD  
 CORROSION PROTECTION. SEE CHART  
 FOR SPECIFIC FINISH.

**WEIGHT:**  
 73.5 KGS. (161.8 LBS.)

# SLG106-5 SLING

**Peck & Hale**<sup>®</sup>  
 Cargo Securing Systems and Solutions

PECK & HALE, L.L.C.  
 180 DIVISION AVENUE  
 WEST SAYVILLE, NY 11796  
 USA

THIS DRAWING AND ANY PRINT MADE THEREFROM IS THE EXCLUSIVE PROPERTY OF PECK & HALE. IT MUST NOT BE TRACED NOR REPRODUCED IN ANY MANNER NOR SHALL IT BE SUBMITTED TO OUTSIDE PARTIES FOR EXAMINATION WITHOUT OUR WRITTEN CONSENT. IT SHALL BE USED ONLY AS MEANS OF REFERENCE TO WORK DESIGNED OR FURNISHED BY US.

3	WIRE ROPE ASSEMBLY	STEEL, GALVANIZED
2	SPREADER BAR	
1	SPREADER BAR	
ITEM NO.	PART NAME	PART DESCRIPTION
<b>LIST OF COMPONENTS</b>		

FSCM NO: 94658	DRN: S. JEFFREY	2542	A
DATE: 3/3/17	CHK:		
SCALE: NONE	APPD:	DWG. NO.	REV.