

SLG173-1 SLING (MK173 MOD 0)

DIMENSIONAL DATA
DIMENSIONS SHOWN IN INCHES AND [MILLIMETERS]
DIMENSIONS ARE REFERENCE ONLY

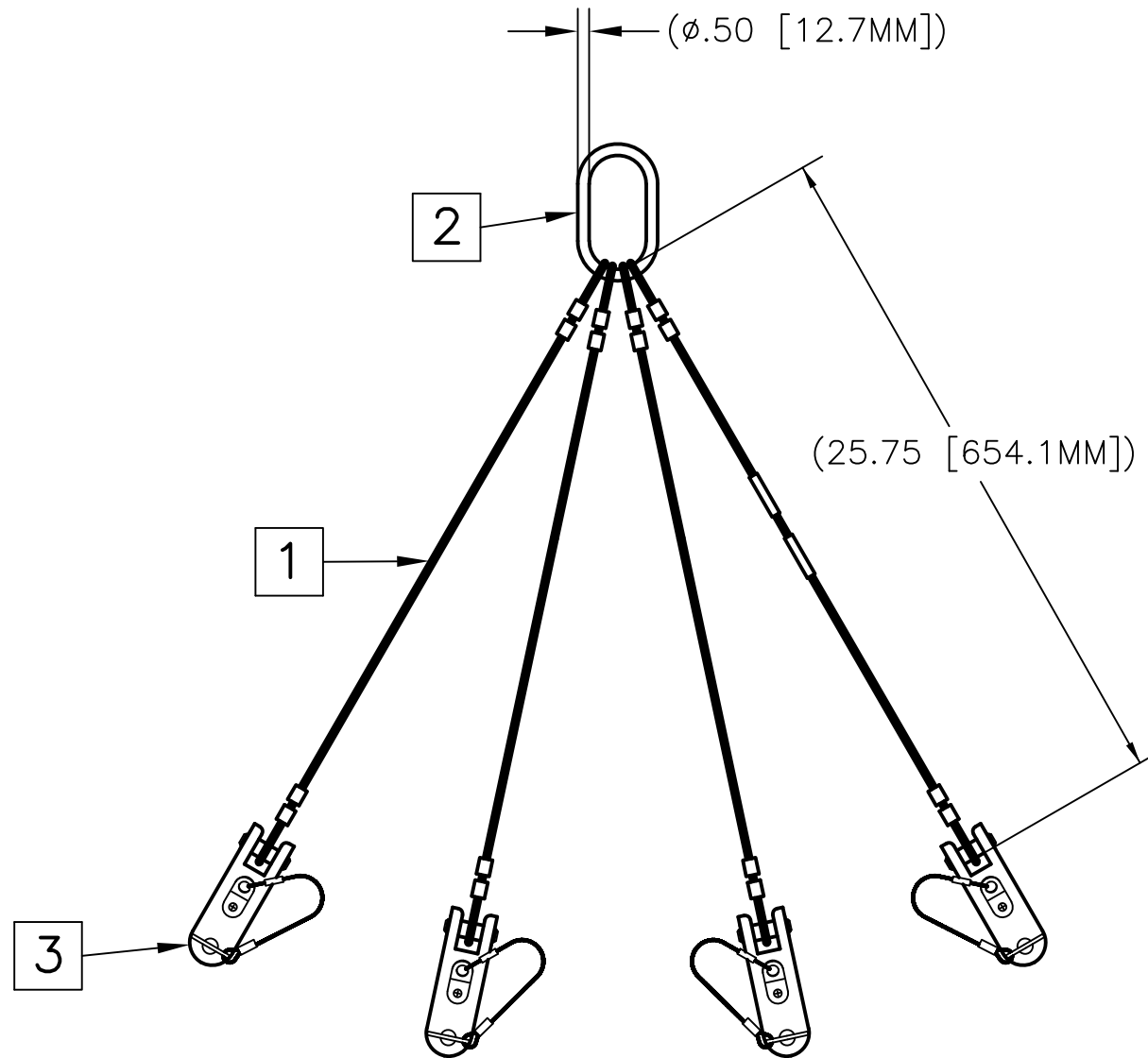

SPECIFICATIONS

MATERIAL:
ALL CONSTRUCTION IS PER BEST COMMERCIAL QUALITY. SEE CHART FOR SPECIFIC MATERIAL.

STRENGTH:
SAFE WORKING-100 LBS.
PROOF-180 LBS.

FINISH:
ALL SURFACE FINISHES PROVIDE GOOD CORROSION PROTECTION. SEE CHART FOR SPECIFIC FINISH.

SLG173-1 SLING (MK173 MOD 0)



PECK & HALE, L.L.C.
180 DIVISION AVENUE
WEST SAYVILLE, NY 11796
USA

THIS DRAWING AND ANY PRINT MADE THEREFROM IS THE EXCLUSIVE PROPERTY OF PECK & HALE. IT MUST NOT BE TRACED NOR REPRODUCED IN ANY MANNER NOR SHALL IT BE SUBMITTED TO OUTSIDE PARTIES FOR EXAMINATION WITHOUT OUR WRITTEN CONSENT. IT SHALL BE USED ONLY AS MEANS OF REFERENCE TO WORK DESIGNED OR FURNISHED BY US.

3	BRACKET	STEEL, ZINC PLATED
2	LINK	STEEL, OBLONG, ZINC PLATED
1	WIRE ROPE	STAINLESS STEEL
ITEM NO.	PART NAME	PART DESCRIPTION

LIST OF COMPONENTS

FSCM NO: 94658	DRN: S. JEFFREY	4751	A
DATE: 3/3/17	CHK: J. NAIR		
SCALE: NONE	APPD: J. NAIR	DWG. NO.	REV.